

Aufbauanweisung (bitte aufbewahren)

NL Opbouwinstructies (A.u.b. bewaren)
FR Consignes d'assemblage (à conserver)
GB Directions for assembly (please save it)
HR Uputa sastavljanja (obavzno sačuvajte)
SI Navodila za sestavljanje (Skrbno shranite)
HU Összeszerelési útmutató (kéjük megőrizni)
SK Návod na montáž (prosím uschovať)
CZ Návod k montáži (uložte si ho prosím)
BG Инструкция за сглобяване (Моля запазете настоящата инструкция)
RO Instrucțiuni de montaj (vă rugăm, păstrați documentul)

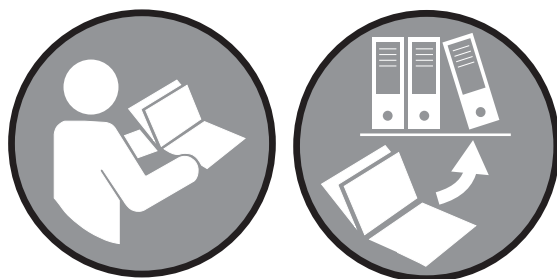

UE5

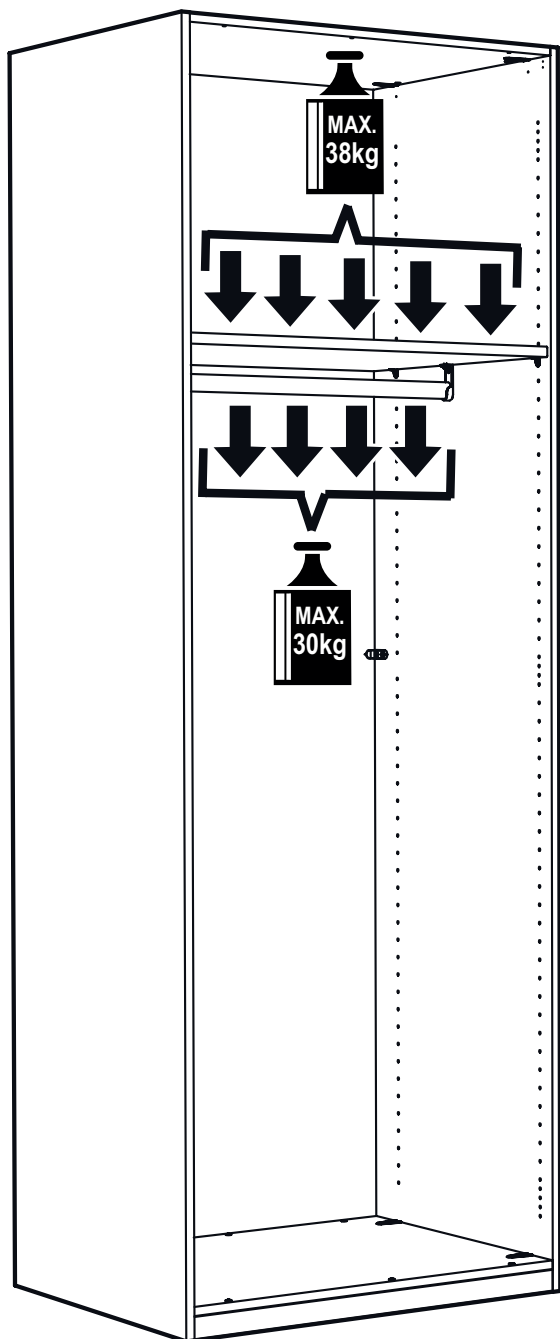

<https://www.express-moebel.com/aufbau-montage/>

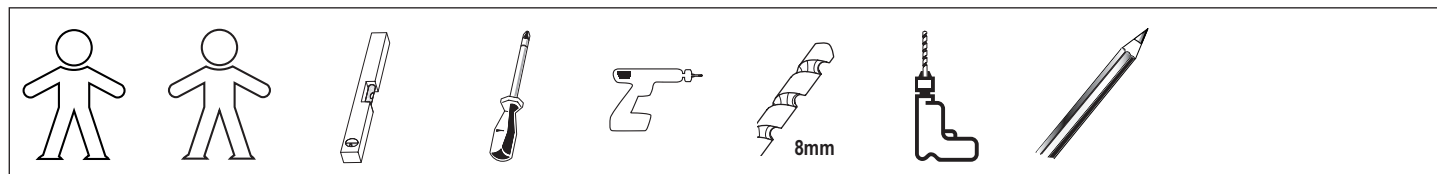
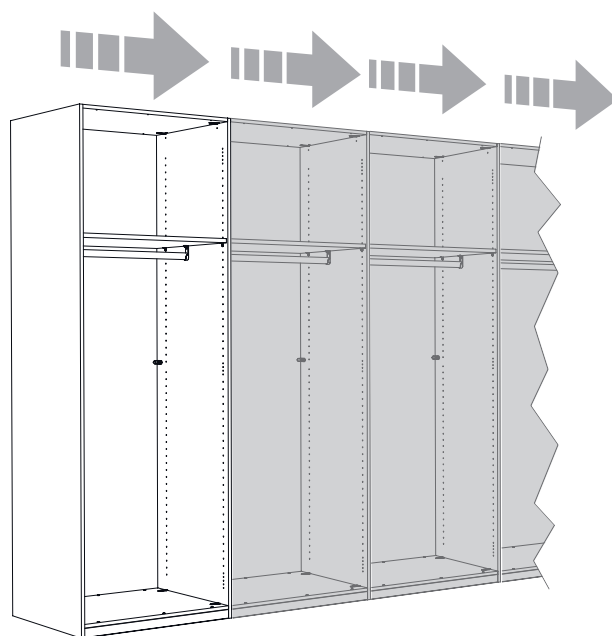
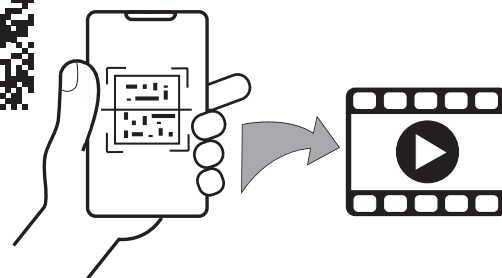

1



**FIRST
STEP!**

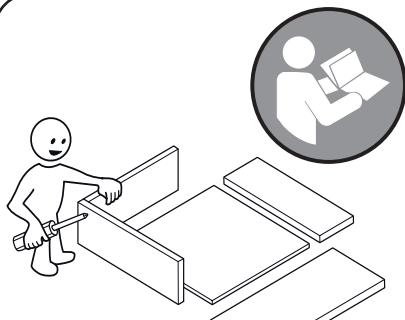
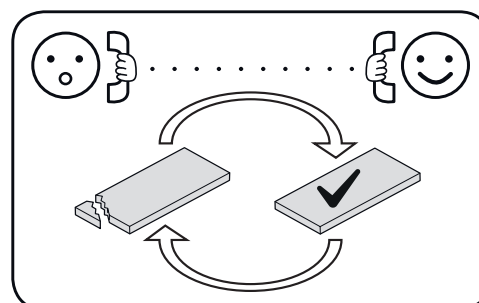
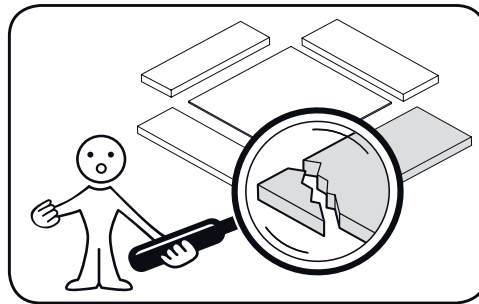
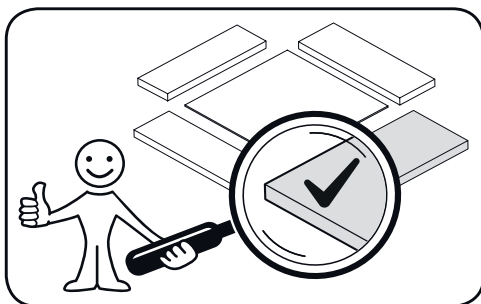

**Lesen Sie zuerst die Aufbauanweisung
und beginnen Sie dann mit der Montage.**

**Die Montage muss exakt nach dieser Anleitung erfolgen,
eine fehlerhafte Montage kann zu einem Sicherheitsrisiko führen.**

**Bei nicht vorschriftsmäßiger und/oder nicht fachmännischer Montage
wird für Personen- oder Sachschäden keinerlei Haftung übernommen.
Montage nur durch Fachkräfte für Möbelmontage (FMKU)!**

- NL** Voordat uw met de montage begint, a.u.b. de opbouw instructies lezen. De montage moet precies volgens deze instructies worden uitgevoerd, onjuiste montage kan leiden tot een veiligheidsrisico. In geval van persoonlijke ongelukken en materiële schade is aansprakelijkheid uitgesloten, indien de montage niet overeenkomstig de voorschriften en/of niet door een vakman werd uitgevoerd. Montage alleen door specialisten!
- FR** Avant de commencer avec le montage, nous vous prions de bien lire les consignes d'assemblage. Le montage doit être effectué exactement selon ces instructions, un assemblage incorrect peut entraîner un risque pour la sécurité. Nous déclinons toute responsabilité en cas de dommages corporels ou matériels dus à un montage non conforme aux instructions et/ou exécuté incorrectement. A ne faire monter que par les équipes spécialisées!
- GB** Before starting with the fitting, please read carefully the directions for assembly. The assembly must be carried out exactly according to these instructions, incorrect assembly can lead to a safety hazard. We will not accept any liability in case of personal injury or material damages, if not assembled according to the regulations and/or by specialists. To be mounted only by mounting teams!
- HR** Prije montiranja pročitajte uputu za sastavljanje. Skupština se mora obaviti točno prema ovom priručniku, netočna instalacija može dovesti do sigurnosnog rizika. U slučaju nzzepropisane i/ili ne stručne montaže ne preuzimamo odgovornost za nastanak štete osobama ili zstvarima. Montaža samo uz pomoć stručne osobe!
- SI** Najprej preberite navodila za sestavljanje in šele nato pričnite z montažo. Montažo je treba opraviti natančno v skladu s temi navodili, nepravilna montaža lahko povzroči varnostno tveganje. Pri montaži brez upoštevanja navodil in/ali pri nestrokovni montaži se ne prevzame nikakršne odgovornosti za telesne poškodbe ali materialno škodo. Montaža samo s strani strokovnjakov!
- HU** Olvassa el először az összeszerelési útmutatót, és csak ezután kezdje el a szerelést. Az összeszerelést pontosan ezen utasítások szerint kell elvégezni, a helytelen összeszerelés biztonsági kockázatot jelenthet. A nem előírás szerint és/vagy nem szakemberrel végzett összeszerelés esetén felmerülő személyi és anyagi károkért semmilyen felelősséget nem vállalunk. Az összeszerelést csak szakember végezheti!
- SK** Najskôr si prečítajte návod na montáž a až potom začnite s montážou. Montáž sa musí vykonať presne podľa tohto návodu, nesprávna montáž môže viesť k ohrozeniu bezpečnosti. V prípade montáže v rozpore s predpismi a/alebo neodpornej montáže nepreberáme v prípade ujmy na zdraví alebo vecných škôd žiadnu zárukuzzvz. Montáž smú vykonávať iba odborníci!
- CZ** Návod k montáži si nejdříve přečtěte a pak začněte s montáží. Montáž musí být provedena přesně podle tohoto návodu, nesprávná montáž může vést k ohrožení bezpečnosti. Při montáži v rozporu s předpisy nebo při neodborné montáži nepřebírá výrobce žádnou záruku za škody vzniklé na osobách nebo předmětech. Montáž smí provádět jen kvalifikovaný personál!
- BG** Първо прочетете инструкцията за сглобяване и след това започнете с монтажа. Монтажът трябва да се извърши точно според тези инструкции, неправилният монтаж може да доведе до опасност за безопасността. Ако монтажът не е извършен съгласно инструкцията и/или от специалисти, фирмата не поема отговорност в случай на нараняване на хора или при материални щети. Монтажът трябва да се извършва само от специалисти!
- RO** Mai întâi citiți instrucțiunile de montaj, și numai după aceea începeți montajul. Asamblarea trebuie efectuată exact în conformitate cu aceste instrucțiuni, asamblarea incorectă poate duce la un risc de siguranță. În caz de montaj efectuat necorespunzător și/sau neprofesionist nu ne asumăm niciun fel de responsabilitate pentru vătămarea persoanelor sau pentru pagubele materiale. Efectuarea montajului este permisă exclusiv specialiștilor!

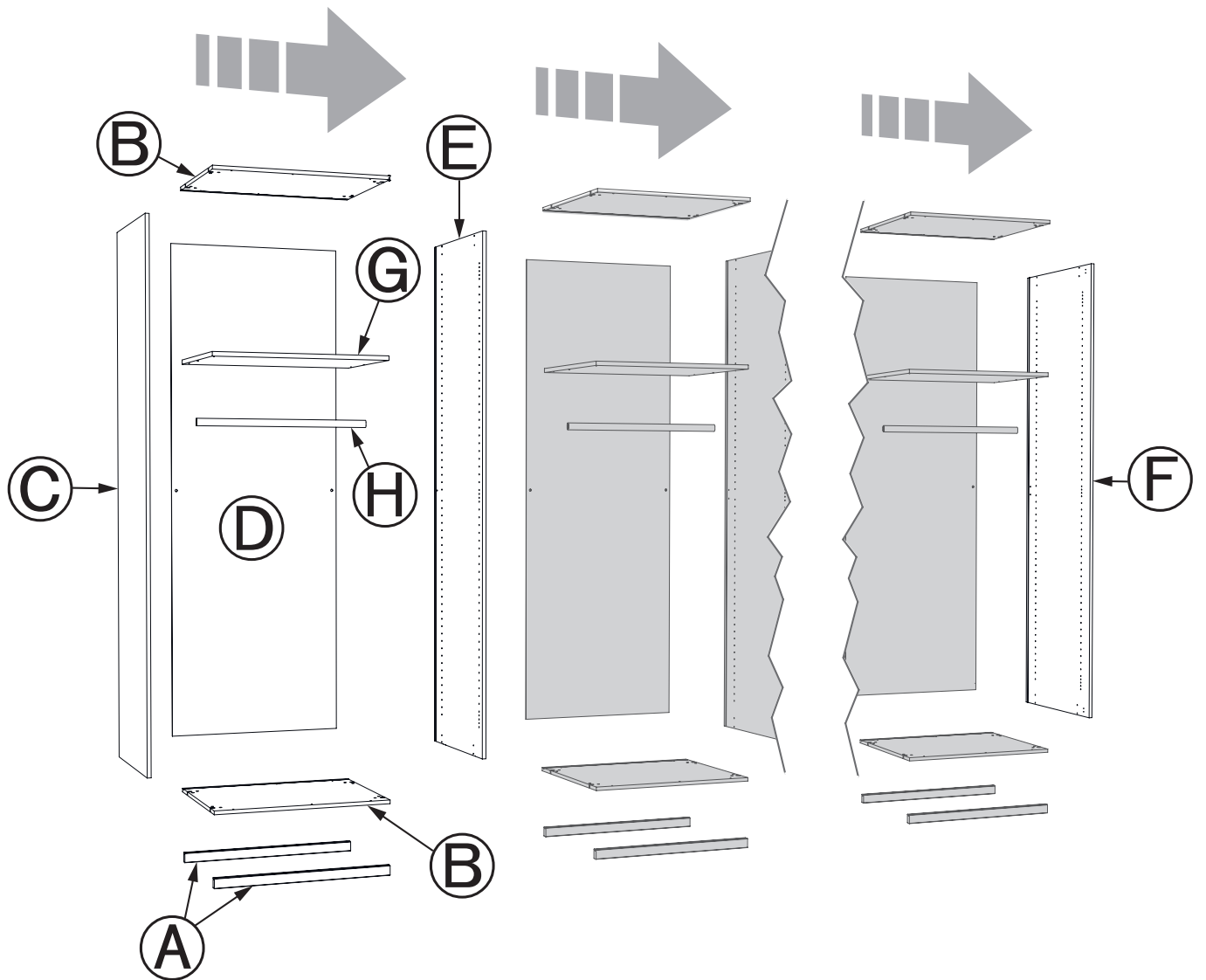

Beschlagsübersicht







NL Beslagoverzicht
FR Tableau de quincaillerie

GB Fitting survey
HR Pregled dijelova

SI Seznam sestavnih delov
HU Kötőelem áttekintés

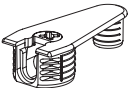
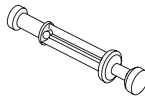
SK Prehľad kování
CZ Přehled kování

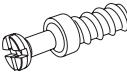
BG Монтажни елементи
RO Vedere de ansamblu

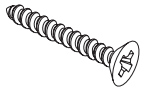
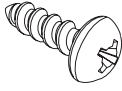
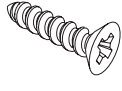
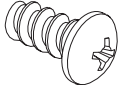
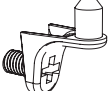
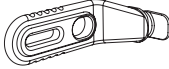
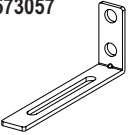
100001  KS-HALTER	100002  SCH-M6*25	100003  QUICKFIT-CAMFIX	100005  Quickfit-Doppelbolzen-16mm	100006  SX4,5*45RW	100016  Schraubdübel-11mm	100501  DUEB-8MM	100502  SX5,0*45FLAKO
100507  SX5,0*15RUKO	165150  SX3,5*16FLAKO	165160  EU6,3*12HRUKO	517710  BOTR-STIFT/EU	527690  RW-WINKEL/MET-VORSPAN	573057  WINKEL-100/40/16-WANDBEF		

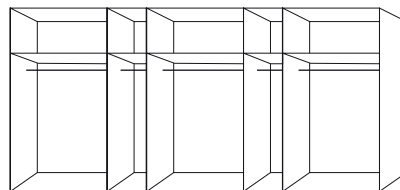
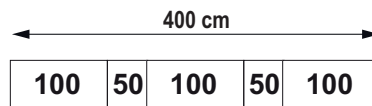
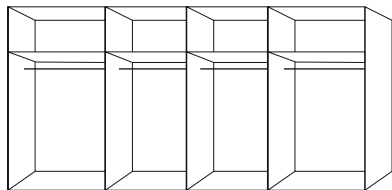
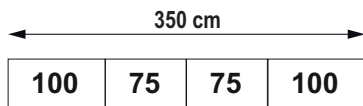
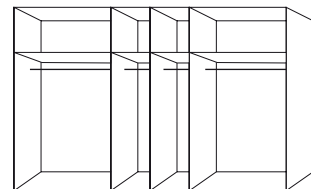
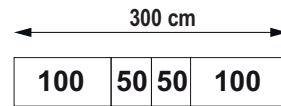
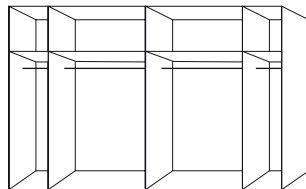
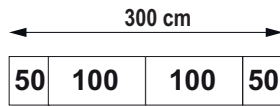
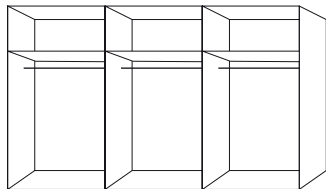
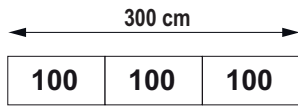
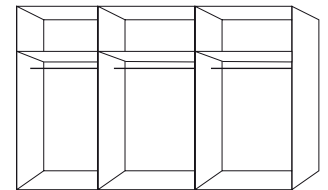
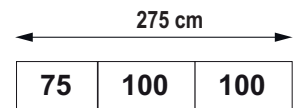
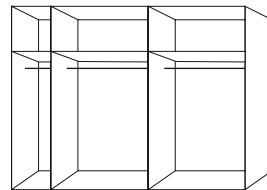
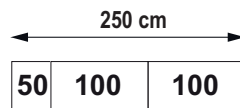
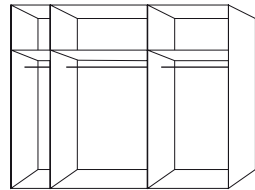
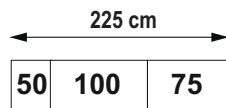
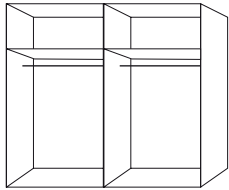
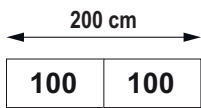
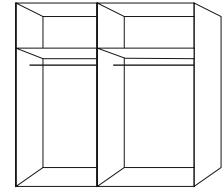
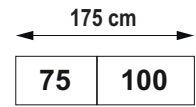
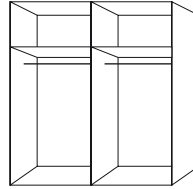
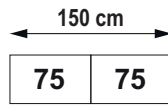
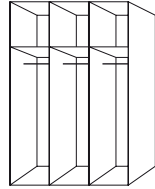
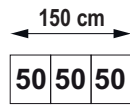
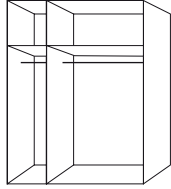
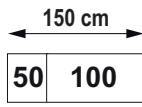
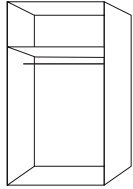
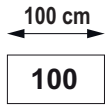

2

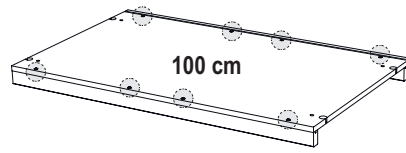
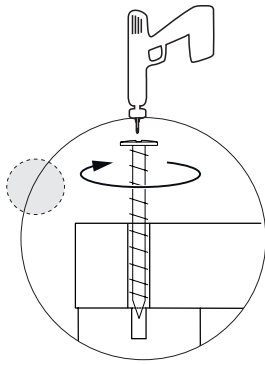

100006 8x
SX4,5*45RW

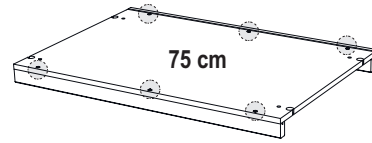

100006 6x
SX4,5*45RW

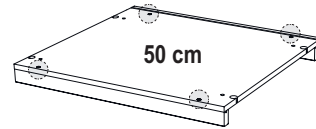

100006 4x
SX4,5*45RW

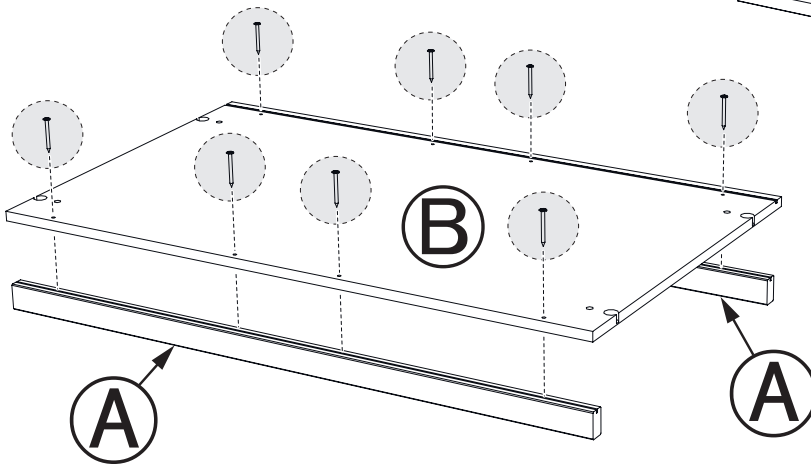

3

100003 4x
QUICKFIT-CAMFIX

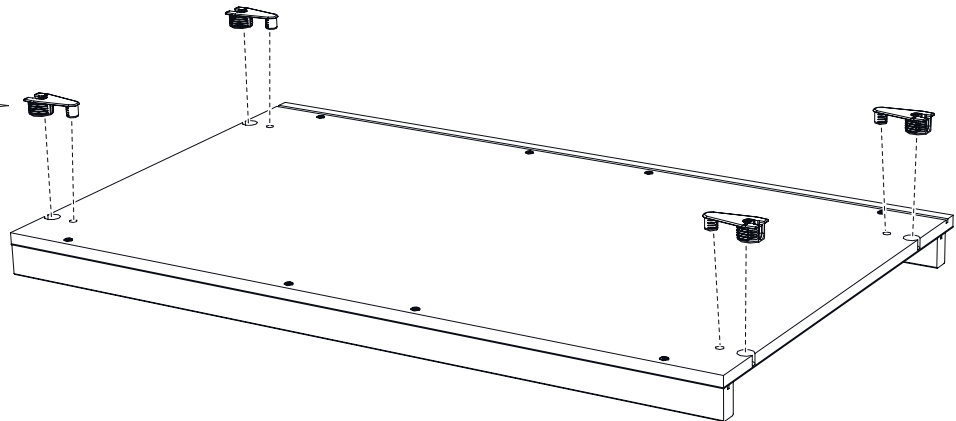
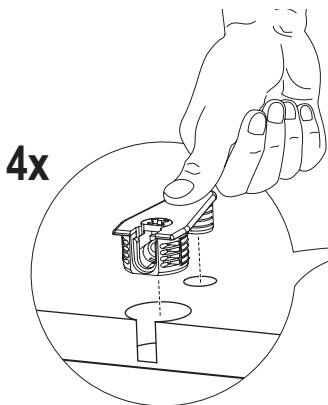

4

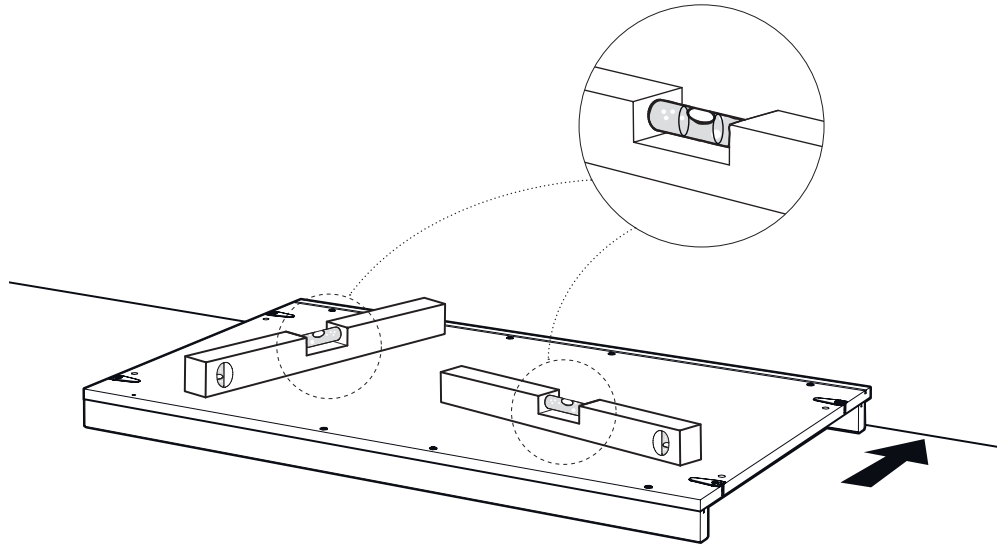

5

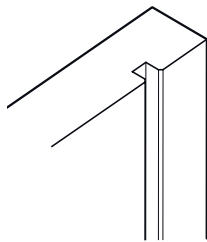

Aussenseite

- NL Buitenzijde
- FR Côté extérieur
- GB End panel
- HR Vanjska stranica
- SI zunanja stranica
- HU külső oldal
- SK vonkajšia strana
- CZ vnější strana
- BG външна преграда
- RO Panou exterior

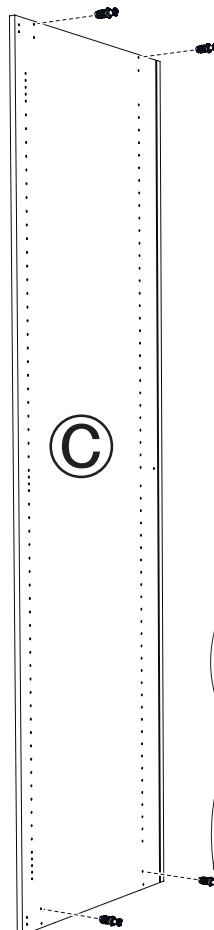

100016 **4x**

Schraubdübel-11mm

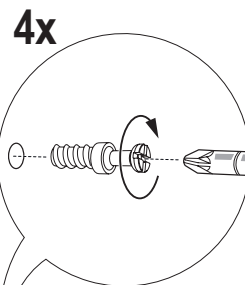

6

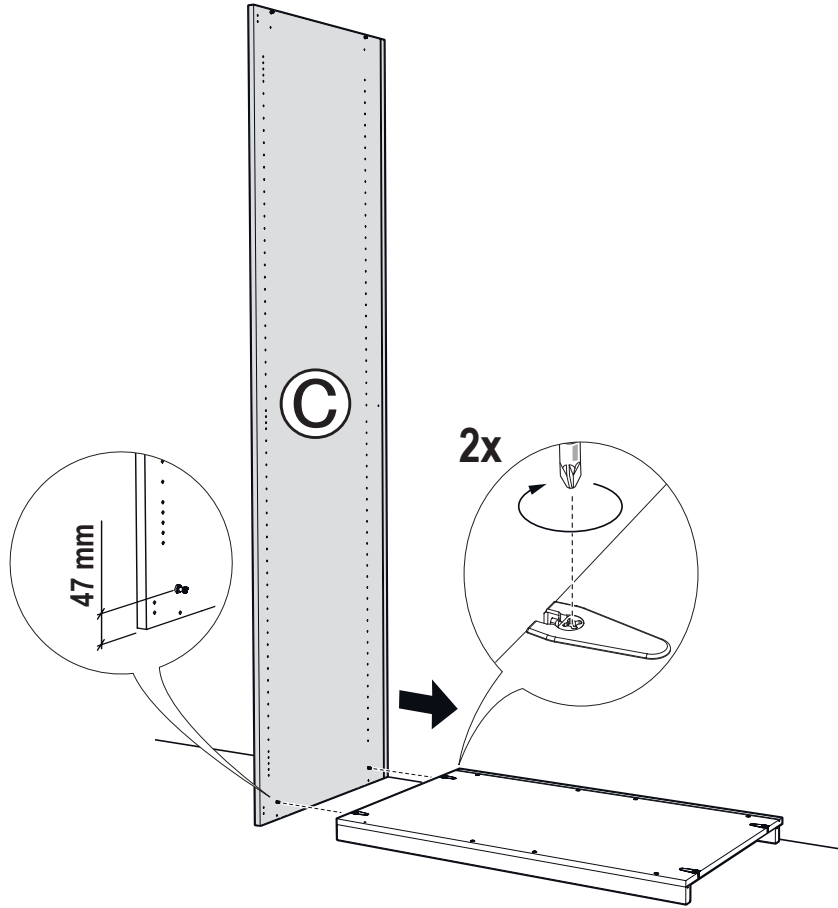

7

527690	1x	165150	1x	165160	1x
RW-WINKEL/MET-VORSPAN		SX3,5*16FLAKO		EU6,3*12HRUKO	

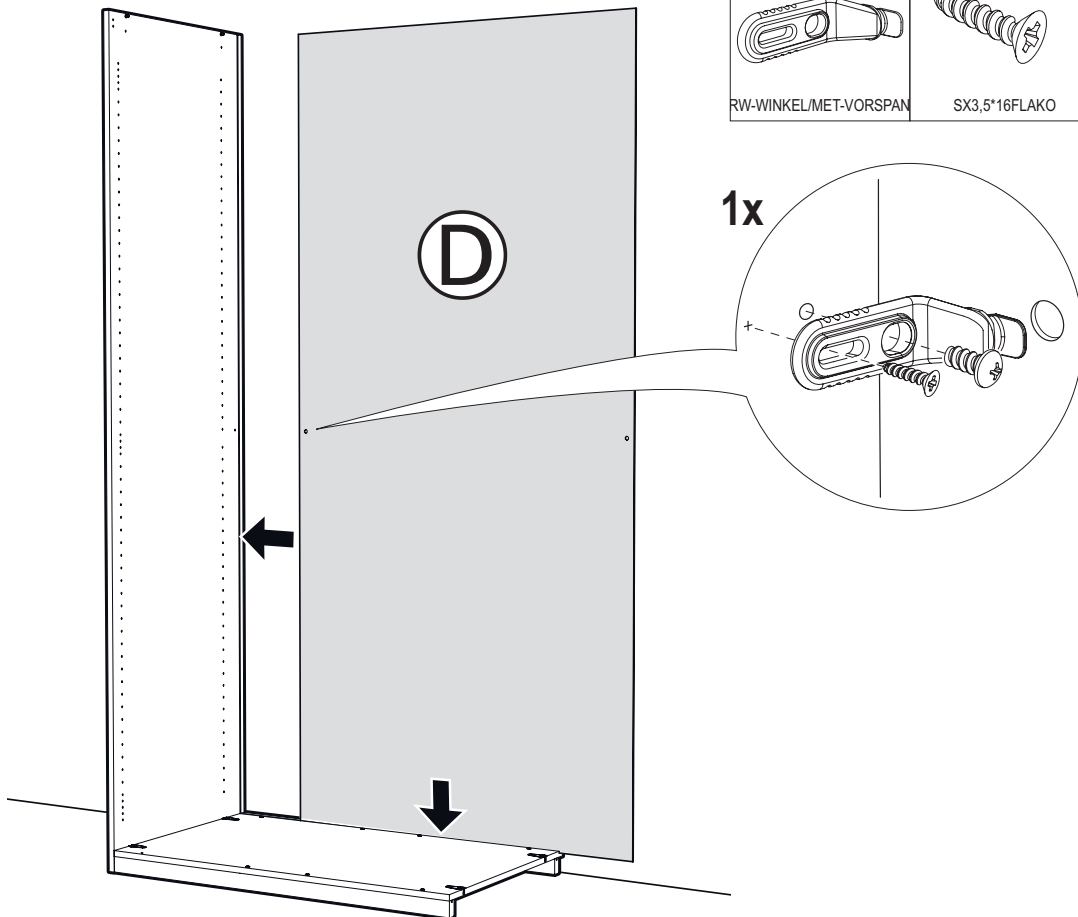

8

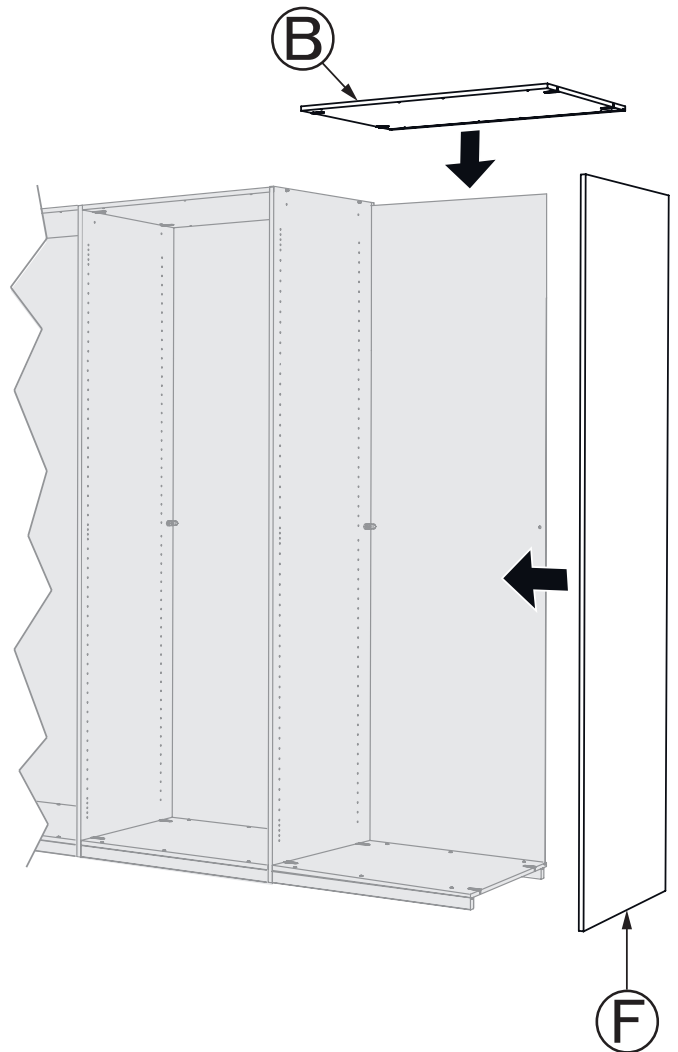
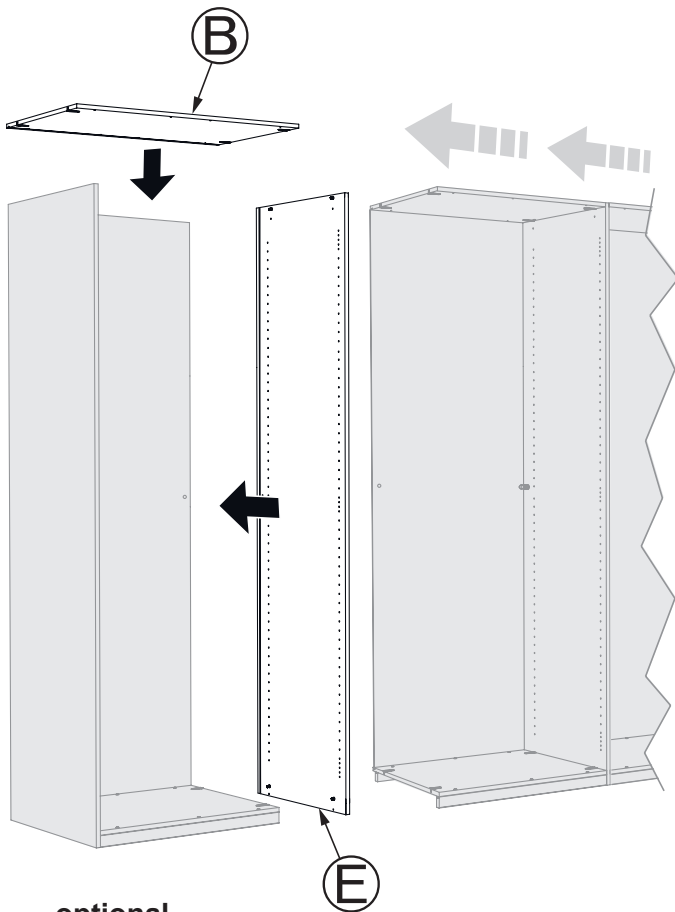

optional

- NL facultatief
- FR optionnel
- GB optional
- HR izborni
- SI neobvezno
- HU választható
- SK voliteľný
- CZ volitelný
- BG по избор
- RO facultativ

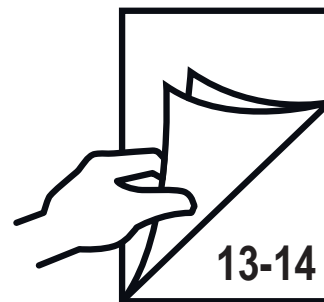
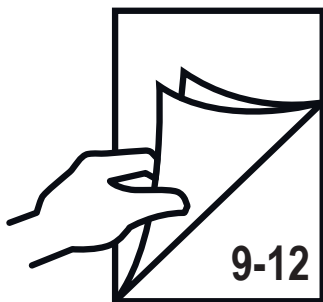

9

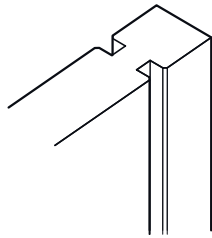

Mittelseite

- NL Middenzijde
- FR Cloison de séparation
- GB Middle side panel
- HR Srednja stranica
- SI srednja stranica
- HU középső oldal
- SK prostredná strana
- CZ prostřední strana
- BG средна преграда
- RO Panou separator

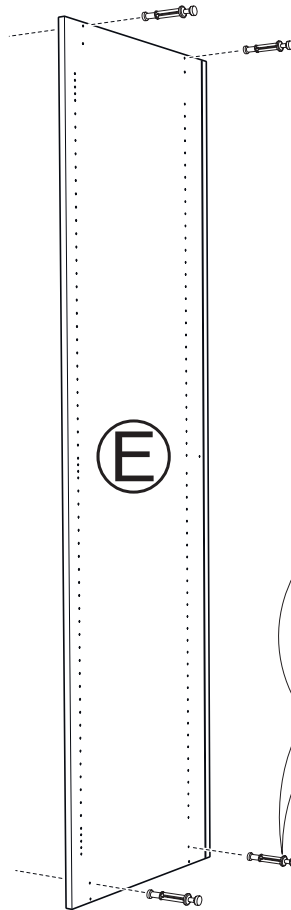

100005 **4x**

Quickfit-Doppelbolzen-16mm

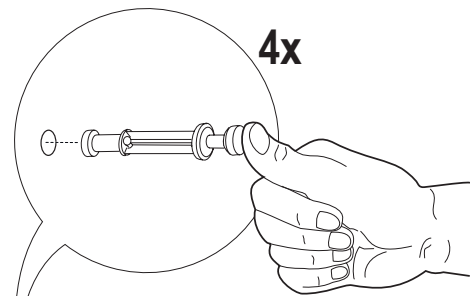

10

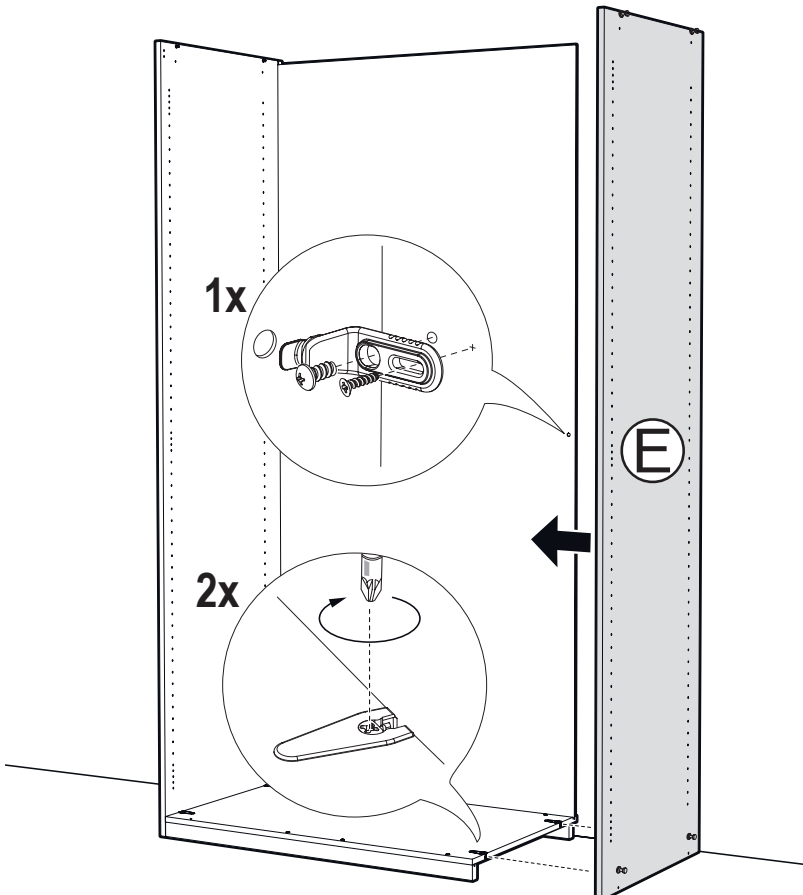

527690 1x	165150 1x	165160 1x
RW-WINKEL/MET-VORSPAN	SX3,5*16FLAKO	EU6,3*12HRUKO

11

100003

4x

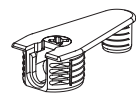

QUICKFIT-CAMFIX

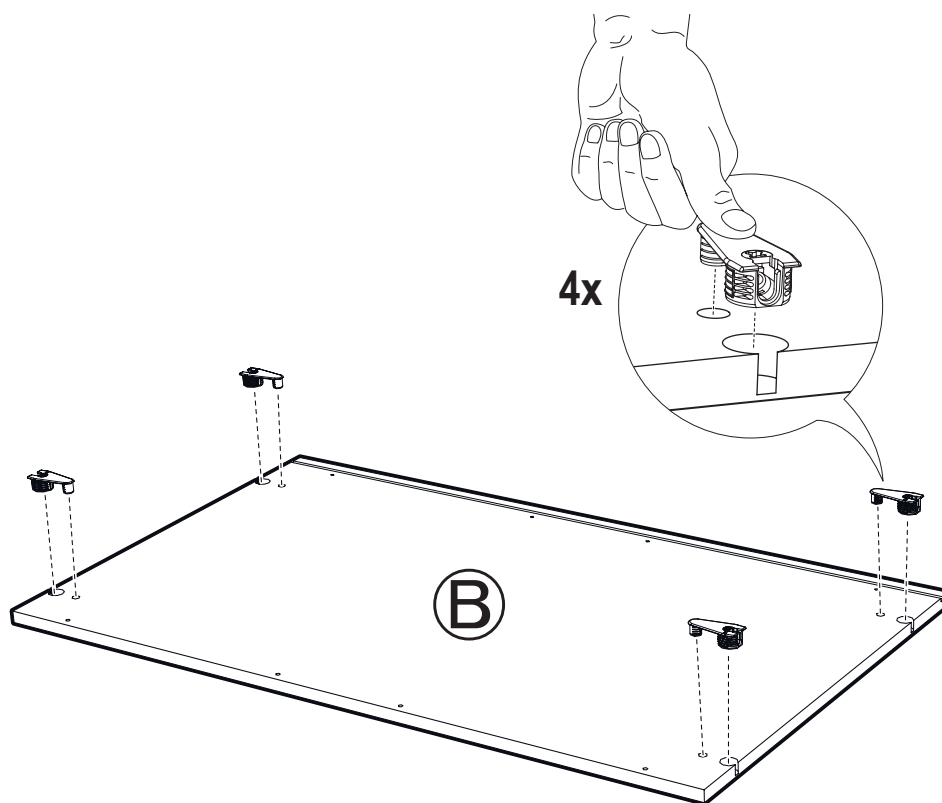

12

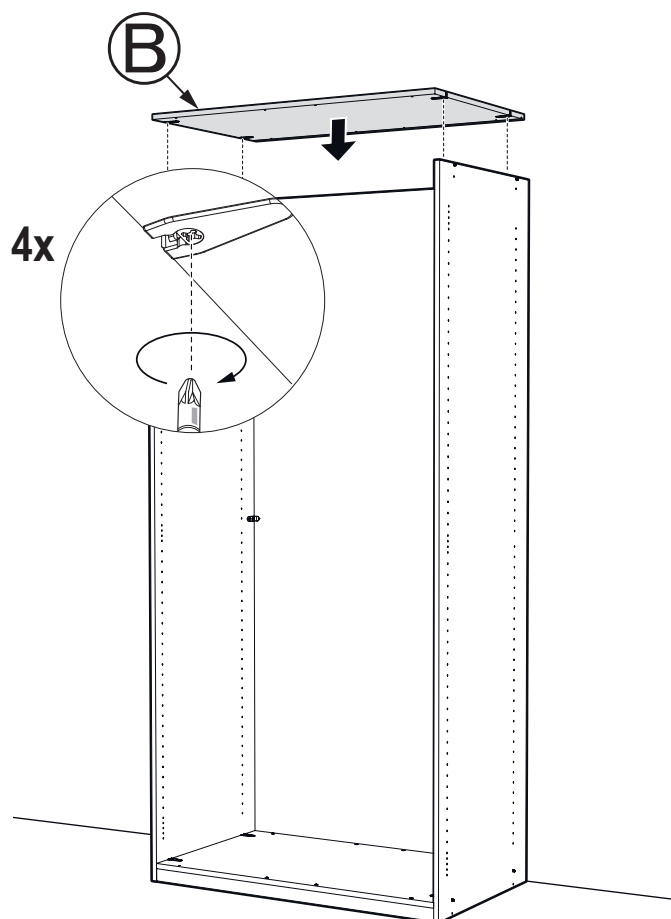

13

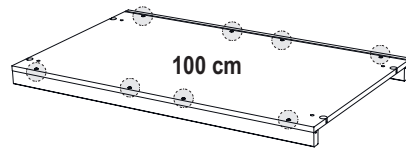
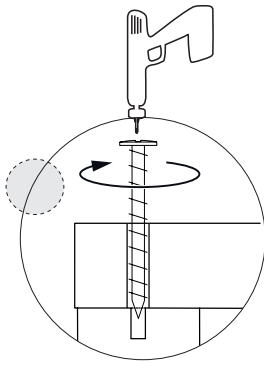

100006 8x
SX4,5*45RW

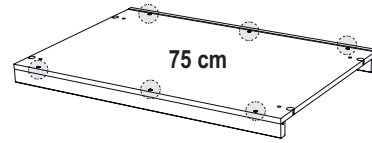

100006 6x
SX4,5*45RW

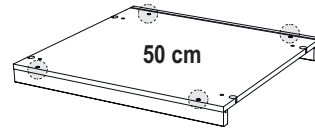

100006 4x
SX4,5*45RW

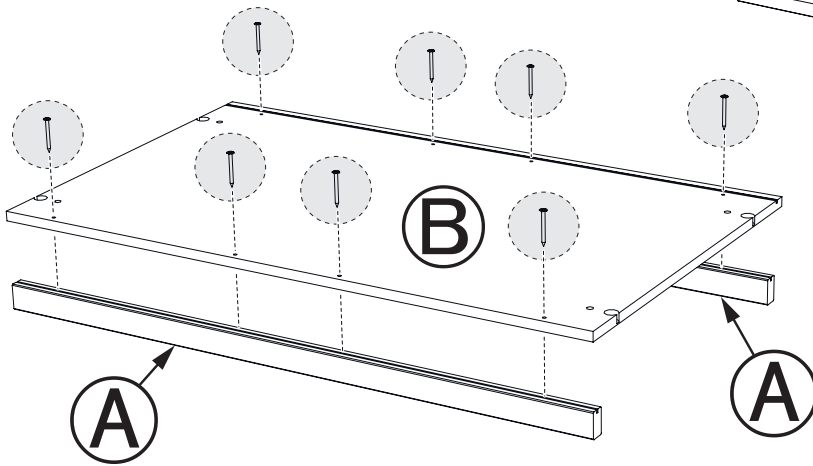

14

100003 4x
QUICKFIT-CAMFIX

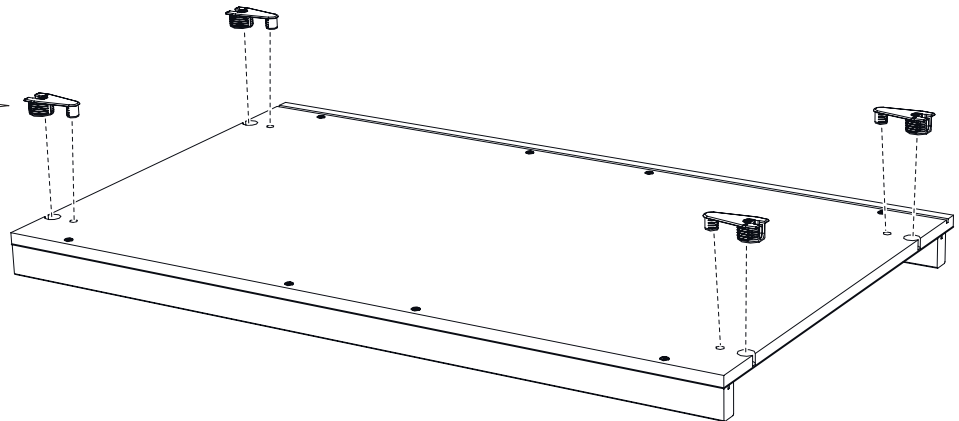
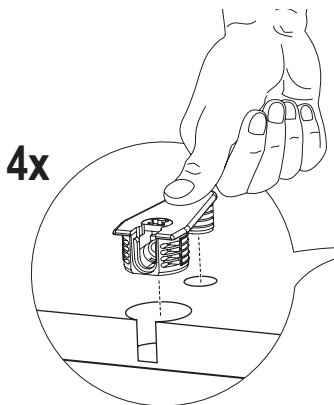

15

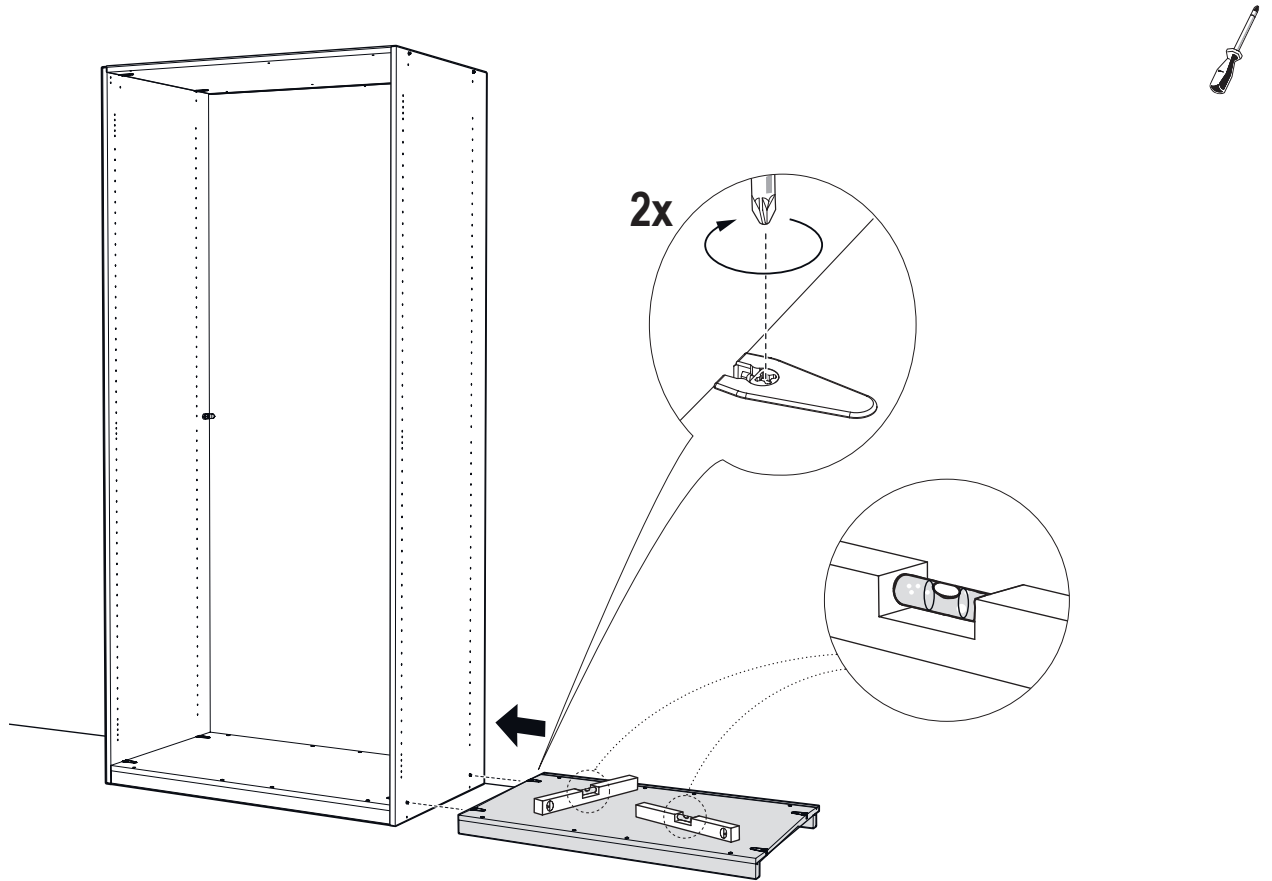

16

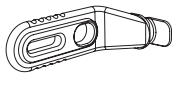
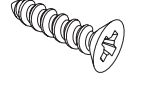
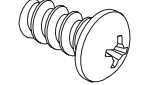
527690	1x	165150	1x	165160	1x
					
RW-WINKEL/MET-VORSPAN		SX3,5*16FLAKO		EU6,3*12HRUKO	

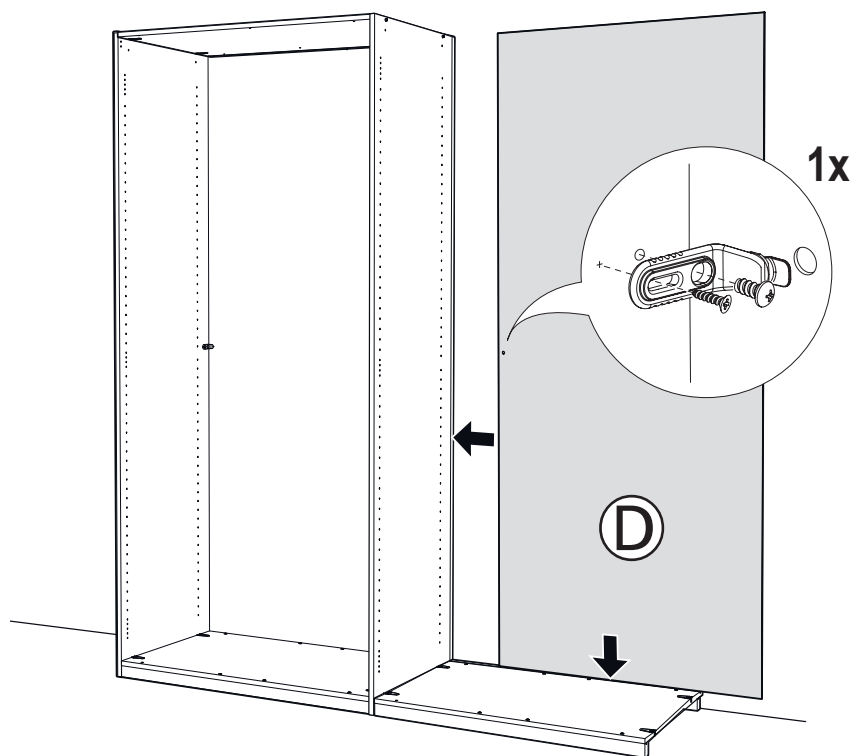

17

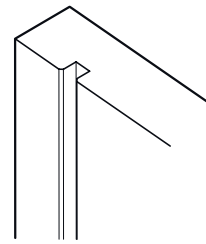
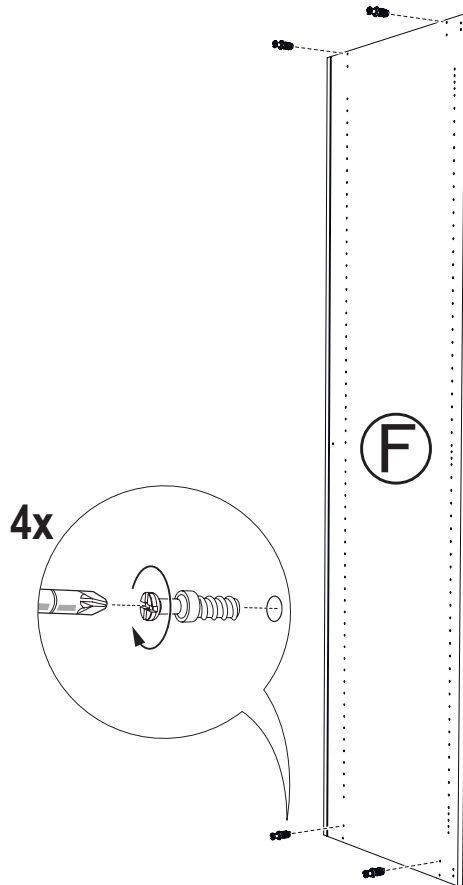

100016 **4x**

Schraubdübel-11mm

Aussenseite

- NL Buitenzijde
- FR Côté extérieur
- GB End panel
- HR Vanjska stranica
- SI zunanja stranica
- HU külső oldal
- SK vonkajšia strana
- CZ vnější strana
- BG външна преграда
- RO Panou exterior



18

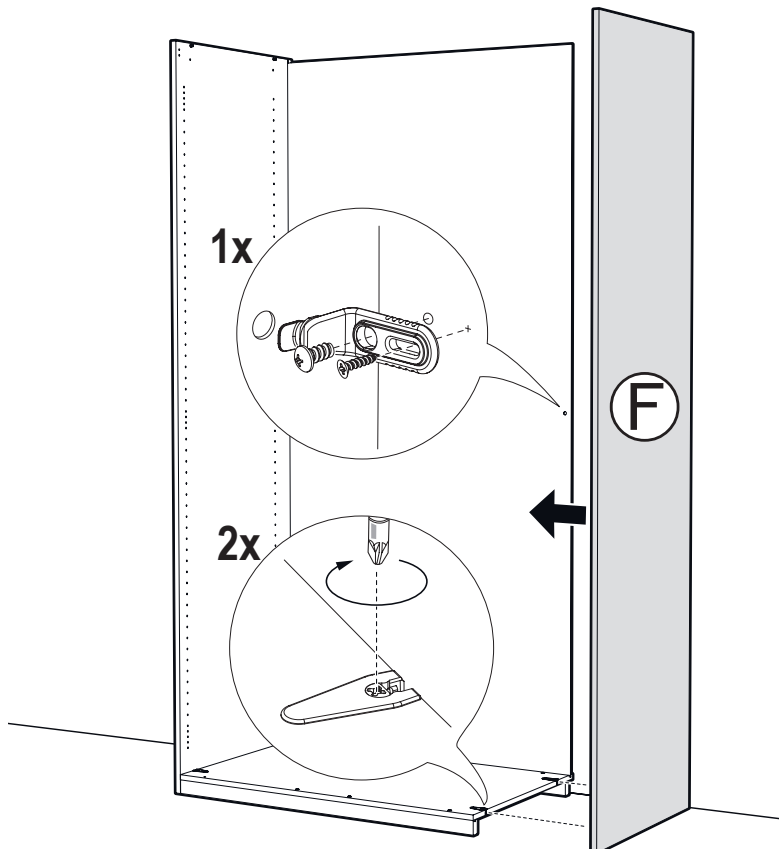

527690 1x	165150 1x	165160 1x
RW-WINKEL/MET-VORSPAN	SX3,5*16FLAKO	EU6,3*12HRUKO

19

100003

4x

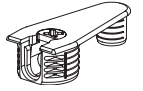

QUICKFIT-CAMFIX

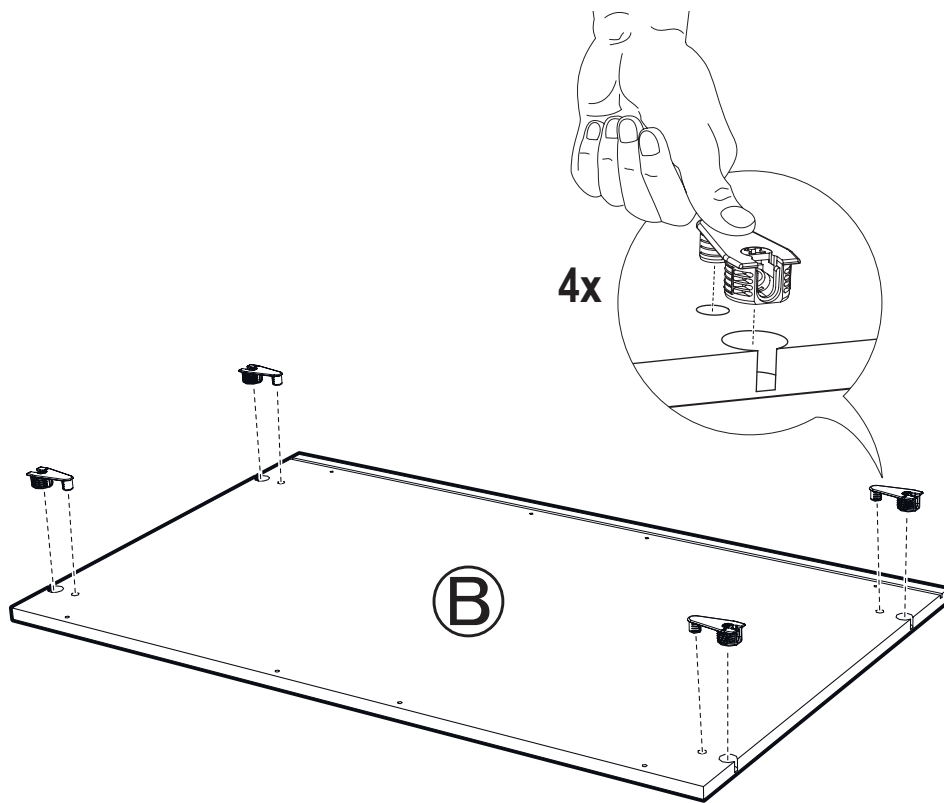

20

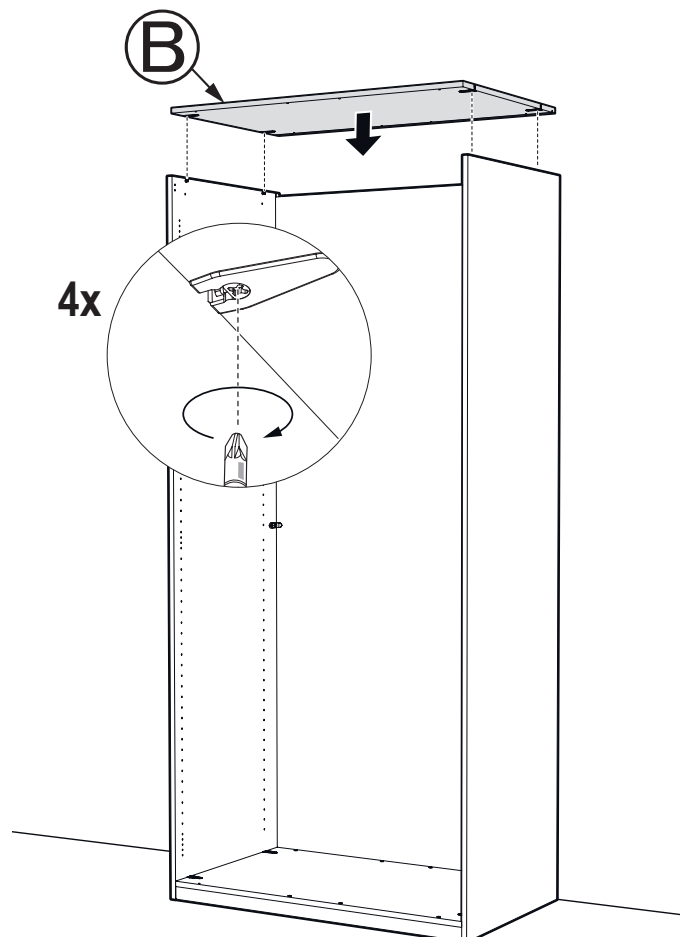

21

517710

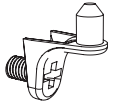

BOTR-STIFT/EU

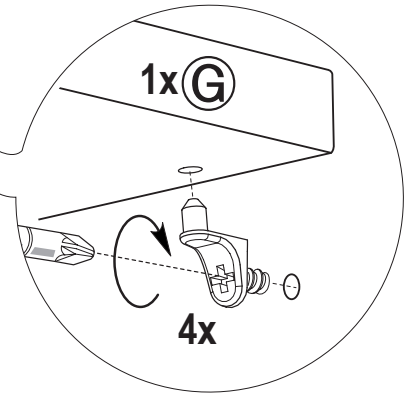
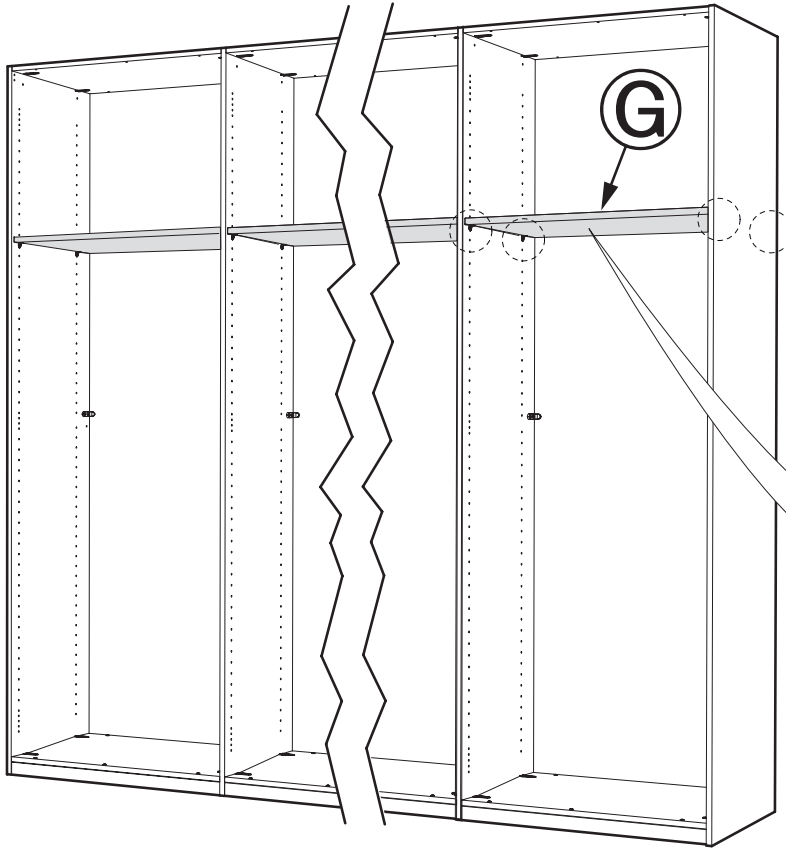

22

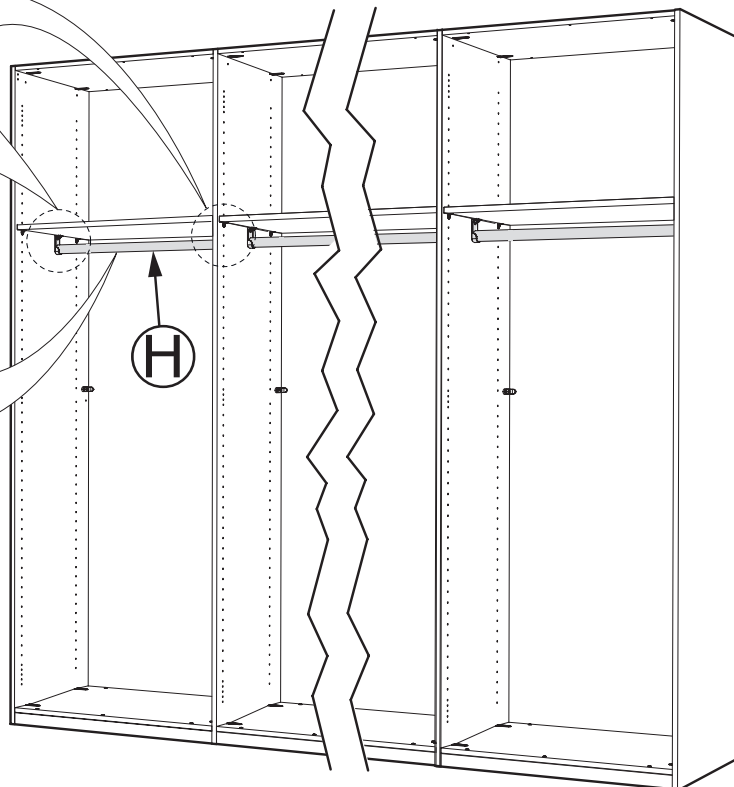
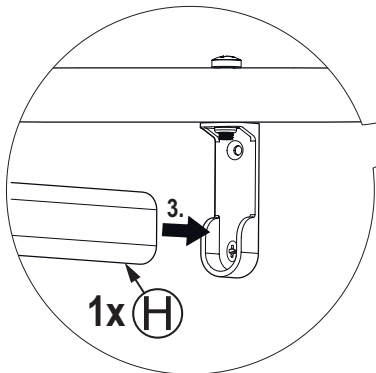
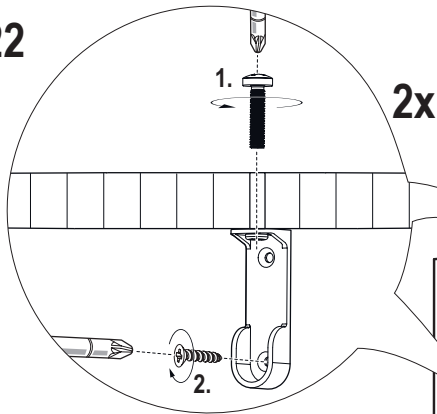

100001



KS-HALTER

100002

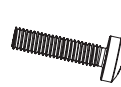

SCH-M6*25

165150

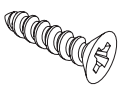

SX3,5*16FLAKO





ACHTUNG!

Aus Sicherheitsgründen muss das Möbelteil an der Wand befestigt werden.

Beiliegendes Befestigungsmaterial eignet sich nur für Massivwände.
Für andere Wände müssen Spezialdübel verwendet werden.

- NL LET OP!** Uit veiligheidsoverwegingen moet het meubeldeel aan de wand bevestigd worden. Bijgevoegt bevestigings materiaal is alleen bruikbaar voor massieve wanden. Voor andere wanden moeten speciale schroeven gebruikt worden.
- Z ATTENTION!** Pour des raisons de sécurité le meuble doit être fixé au mur. Le matériel ci-joint est approprié pour des murs épais. Pour d'autres murs utiliser des chevilles spéciales.
- GB ATTENTION!** For safety reasons please fix the unit to the walls. Enclosed fittings for stoned wall only. For other walls please use other pegs.
- HR OPREZI!** Zbog sigurnosnih razloga namještaj morate pričvrstiti na zid. Materijal za pričvršćivanje koji je u pravitku pričvrstiti možete samo na masivne zidove. Za ostale vrste zidova morate koristiti posebne tiplove.
- SI POZOR!** Iz varnostnih razlogov je potrebno del pohištva pritrčiti na steno. Priložen material za pritrčitev je primeren samo za masivne stene. Za druge stene je potrebno uporabiti posebne vložke.
- HU FIGYLEM!** Biztonsági okokból a bútordarabot a falhoz kell erősíteni. A mellékelt rögzítőanyag csak masszív falaknál alkalmazható. Egyéb falaknál speciális tiplít kell használni.
- SK POZOR!** Z bezpečnostných dôvodov musí byť táto časť nábytku pripevnená na stenu. Priložený materiál na upevnenie sa hodí len pre masívne steny. Pre ostatné druhy stien použite špeciálne hmoždinky.
- CZ POZOR!** Z bezpečnostních důvodů musí být nábytek upevněn ke stěně. Příložený materiál k upevnění ke stěně je vhodný pouze k použití na masivních zdech. Na jiné stěny musí být použity speciální hmoždinky.
- BG ВНИМАНИЕ!** От съображения за сигурност мебелите трябва да бъдат закрепени към стената. Приложените закрепващи приспособления са подходящи само за масивни стени. За други видове стени трябва да се използват специални дюбели.
- RO PERICOL** Din motive de siguranță, piesa de mobilier trebuie fixată pe perete. Materialul de fixare inclus în pachetul de livrare este adecvat numai pentru pereții masivi. Pentru alte tipuri de pereți trebuie utilizate dibluri speciale.

100501



DUEB-8MM

100502



SX5,0°45FLAKO

100507

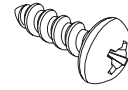

SX5,0°15RUKO

573057

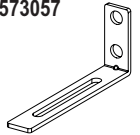

WINKEL-100/40/16-WANDBEF

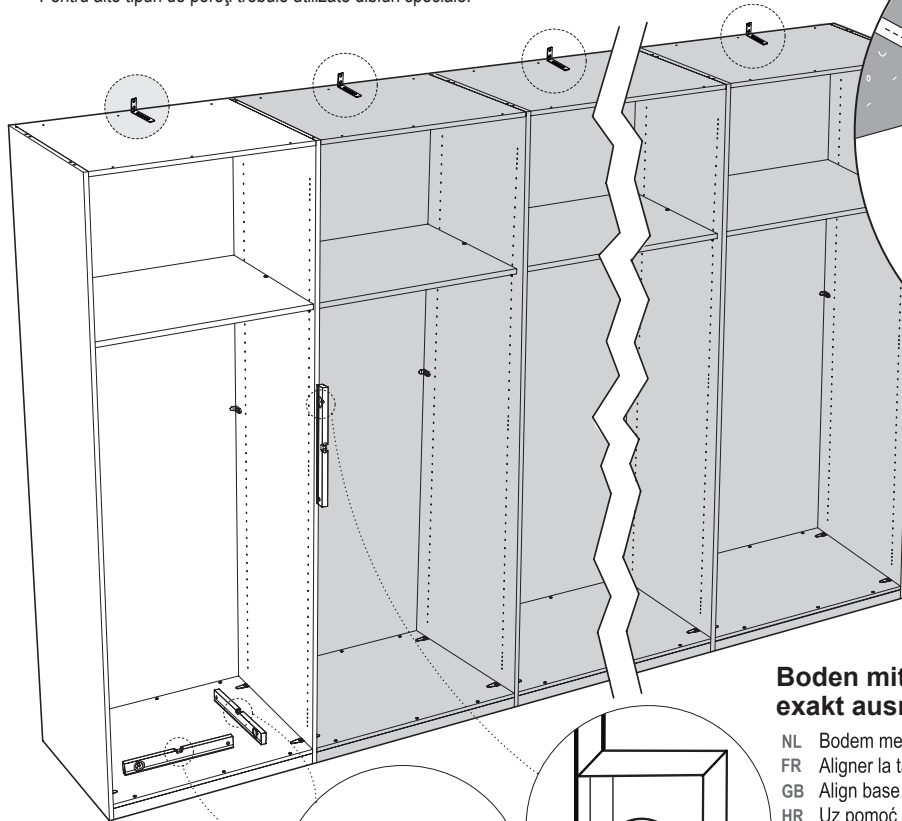
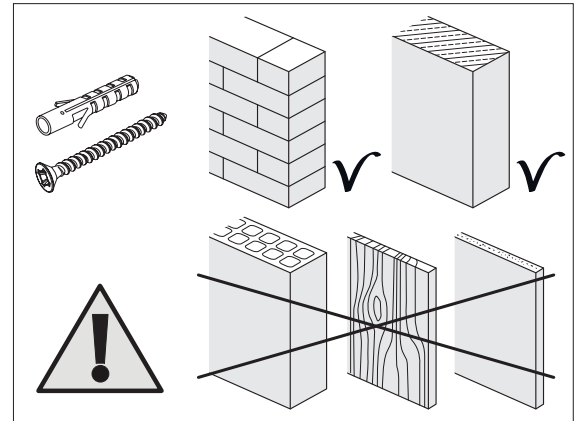

Boden mit Wasserwaage nach allen Richtungen exakt ausrichten!

- NL** Bodem met waterpas horizontaal plaatsen!
- FR** Aligner la tablette avec le niveau à bulle d'air
- GB** Align base unit with a spirit level!
- HR** Uz pomoć libele poravnajte pod u svim smjerovima!
- SI** Tla izravnavajte z libelo natančno v vse smeri!
- HU** A talajt vízszintezővel minden irányban pontosan ki kell egyenesíteni.
- SK** S pomocou libely skontrolujte, či je Vaša podlaha rovná na všetkých miestach.
- CZ** Dno přesně vyrovnejte vodováhou ve všech směrech!
- BG** Подравнете прецизно пода във всички посоки с нивелир!
- RO** Aliniați baza dulapului în toate direcțiile cu o nivelă cu bulă de aer!

Servicekarte

NL Servicekaart GB Service card SI Servisna kartica SK Servisná karta BG Сервизна карта
FR Carte de service HR Servisna karta HU Szervíz kártya CZ Servisní karta RO Carte de service

Nolte Möbel GmbH & Co. KG, Konrad-Nolte-Straße 20, 76726 Germersheim, Tel.: +49-7274/51-120, www.nolte-moebel.de

Sorgfalt bei der Produktion und der Endkontrolle garantieren mängelfreie Beschaffenheit unserer Produkte. Sollten Sie dennoch Grund zu einer Mängelrüge haben, so senden Sie bitte diese Servicekarte und bei Bedarf die markierte Aufbauanweisung an Ihren Händler.

- NL Zorgvuldigheid bij de productie en de eindcontrole garanderen dat onze producten vrij zijn van gebreken. Indien u toch klachten heeft, stuur dan alsblijft bijgaande servicekaart en zo nodig de montagehandleiding met toelichting naar uw verkoper.
- FR Nous veillons soigneusement à la qualité impeccable de nos produits pendant la production et avec le contrôle avant le chargement. Si toutefois, vous êtes amenés à nous adresser une réclamation, nous vous prions de nous joindre la carte de service et la notice de montage sur lesquelles vous aurez marqué la pièce en question.
- GB Our production techniques and final quality inspections ensure that our products are faultlessly manufactured. However, if you should have any reason for complaint, please send the service card to your dealer, if necessary enclosing the assembly instructions to indicate the faulty part.
- HR Pozornost prilikom proizvodnje i finalne kontrole jamče besprijekorno stanje naših proizvoda. Imate li ipak osnova za reklamaciju, molimo da tada pošaljete priloženu servisnu kartu i prema potrebi označeno uputstvo za sklapanje vašem trgovcu.
- SI Skbnost pri izdelavi in zaključni kontroli zagotavlja izdelavo naših produktov brez napak. V primeru, da imate razlog za pritožbo, Vas prosimo da svojemu trgovcu pošljete pritrjeno servisno kartico in po potrebi tudi označeno navodilo glede sestavljanja.
- HU A gondosság a gyártás és a végső ellenőrzés során garantálja termékünk hibátlan minőségét. Ha Önnek ennek elnére is oka lenne az áru kellékihiányának bejelentésére, úgy kérem küldje el a mellékelt szervízkartyát és szükség esetén a megjelölt összeszerelési útmutatót kereskedőjének.
- SK Dôslednosť pri výrobe a výstupnej kontrole je zárukou bezchybných vlastností našich výrobkov. Ak však aj napriek tomu máte dôvod na reklamáciu, zašlite priloženú servisnú kartu a v prípade potreby označený návod na montáž svojmu predajcovi.
- CZ Pečlivost během výroby a výstupní kontrola zaručují technicky bezvadné vlastnosti našich produktů. Pokud byste přesto měli důvod k reklamaci, zašlete svému obchodníkovi přiloženou servisní kartu a v případě potřeby také označený návod k montáži.
- BG Прецизността при производството и при крайния контрол гарантират отличното качество на нашите продукти. Ако въпреки това имате основание за reklamacия, моля изпратете на Вашия продавач приложената сервизна карта, а при нужда - маркираната инструкция за сглобяване.
- RO Atenția în timpul producției și la verificarea finală garantează calitatea impecabilă a produselor noastre. Dacă totuși aveți motive de reclamație din cauza unor deficiențe de calitate, trimiteți distribuitorului dumneavoastră cartea de service atașată și - dacă este nevoie - instrucțiunea de montaj marcată.

Typ

UE5 NL Type GB Type SI Tip SK Typ
BG Вид FR Type HR Tip HU Típus CZ Typ RO Tip

Kaufvertragsnummer / Lieferscheinnummer

NL Koopcontract nr. / vervoerdocument nr.
FR No. contrat d'achat / no. bon de livraison
GB Purchase contract no. / delivery note no.
HR Broj prodajnog ugovora / Broj otpavnice
SI Številka kupoprodajne pogodbe / Številka dostavnice
HU Numárul contractului de achiziționare / numărul bonului de livrare
SK Vételi szerződés száma / Szállítólevél száma
CZ Číslo kúpnej zmluvy / číslo dodacieho listu
BG № на договора за продажба / № на деливъри ордера
RO C.kupni smlouvy / číslo dodacieho listu

Datum

NL Date GB Date SI Datum SK Dátum
BG Дата FR Date HR Datum HU Dátum CZ Datum RO Data





Fehlerursache

NL Oorzaak van het gebrek HU Hiba oka
FR Raison de la réclamation SK Príčina chyby
GB Reason for complaint CZ Příčina závady
HR Uzrok greške BG Причина за дефекта
SI Vzrok napake RO Cauza defectiunilor

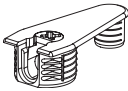
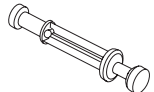
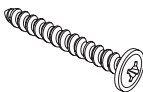
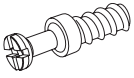

Beschlagsübersicht

NL Beslagoverzicht GB Fitting survey SI Seznam sestavnih delov SK Pehľad kovaní BG Монтажни елементи
FR Tableau de quincaillerie HR Pregled dijelova HU Kötőelem áttekintés CZ Pěhled kování RO Vedere de ansamblu

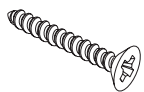
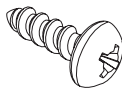
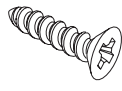
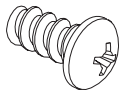
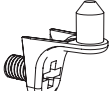
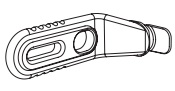
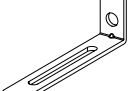
100001  KS-HALTER	100002  SCH-M6*25	100003  QUICKFIT-CAMFIX	100005  Quickfit-Doppelbolzen-16mm	100006  SX4,5*45RW	100016  Schraubdübel-11mm	100501  DUEB-8MM	100502  SX5,0*45FLAKO
100507  SX5,0*15RUKO	165150  SX3,5*16FLAKO	165160  EU6,3*12HRUKO	517710  BOTR-STIFT/EU	527690  RW-WINKEL/MET-VORSPAN	573057  WINKEL-100/40/16-WANDBEF		

Kunden-Information/ Pflegehinweis

NL Consumenteninformatie/ Onderhoud
FR Information clients/ Entretien
GB Customer information/ Maintenance
HR Informacije za kupce/ Uputstvo njege

SI Informacije za stranke/ Navodilo oskrbe
HU Vevőtájékoztató/ Kezelési javaslat
SK Informácia pre zákazníka/ Pokyny na starostlivosť

CZ Informace pro zákazníka/ Pokyny k péči
BG Информация за клиентите/ Указание за поддържане
RO Informații-clienti/ Intreținere

Die fachmännische Montage unserer Möbel wird auf den ausführlichen Aufbauanweisungen Schritt für Schritt dokumentiert. Grundsätzlich erfolgt die Demontage der Möbel in umgekehrter Reihenfolge. Bei der Demontage von elektrischen Bauteilen diese zwingend von der Netzspannung trennen. Beachten Sie auch die ergänzenden Hinweise in den Aufbauanweisungen. Die umweltgerechte Entsorgung unserer Möbel kann über kommunale Verwertung mit der Möglichkeit der Rückführung in den Recycling-Kreislauf erfolgen. Durch eine ordnungsgemäße Entsorgung sparen Sie Ressourcen und schonen die Umwelt.

Oberflächen Kunststoff-Dekor Holznachbildung. Mit leicht feuchtem Tuch reinigen, sofort trocken nachwischen. Möbel nicht für Feuchträume geeignet (Bad, Küche etc.). Nässe auf Oberfläche unverzüglich wegwischen.

- NL Oppervlakte kunststofdecor houtstructuur. Met licht vochtige doek reinigen en hierna direct droog wrijven. De meubels zijn niet voor vochtige ruimten (bad, keuken etc.) bestemd. Vocht op het bovenblad direct opnemen.
- FR Panneaux de particules revêtus d'un film polymère. Utiliser un chiffon légèrement humide et repasser de suite avec un autre sec. Meuble inadapté aux pièces humides (bain, cuisine etc.). Toute trace de liquide est à essuyer immédiatement.
- GB All surfaces in laminated wood colour finishes. Clean with slightly moistened cloth, wipe dry immediately. Not suited for damp locations (kitchen, bathroom etc.). Wipe off wetness at once.
- HR Površine plastična materija-dekor-drvena imitacija. Čistiti sa lako namokrenom krpom, odmah suho obrisati. Namještaj nije pogodan za vlažne prostorije (kupatilo, kuhinju itd.). Vlažnost iz površine odmah obrisati.
- SI Zgornje površine umetne sestavine- Dekor-Lesno nadomestilo. Z rahlo vlažno krpo čistiti, takoj na suho obrisati. Pohištvo ni primerno za vlažne prostore (Kapalnica, Kuhinja itd.). Mokroto na površini takoj obrisati vstran.
- HU Müanyag-dekor felület, fanyomatos mintázattal. Tisztítás enyhén nedves ruhával, majd azonnal szárazra törölni. A bútor nem ajánlott nedves helyiségekbe (pl. fürdőszoba, konyha). A felületre került nedvességet azonnal törölniük le.
- SK Povrch z umelej hmoty v dekoré imitácie dreva. Čistiť zľahka navlhčenou handričkou a ihneď utrieť do sucha. Nábytok nie je vhodný do vlhkých miestností (do kúpelne, kuchyne atď.). Vlhkosť na povrchu nábytku okamžite utrieť.
- CZ Povrch z umělé hmoty v dekoru imitace dřeva. Čistit lehce navlhčeným hadrem a ihned utřít do sucha. Nábytek není vhodný do vlhkých místností (do koupelny, kuchyně atd.). Vlhkost na povrchu nábytku neprodleně utřít.
- BG Повърхност изкуствена материя - декор - имитация на дърво. Да се почиства с влажна кърпа, веднага да се подсушава. Мебелите не са подходящи за влажни помещения (баня, кухня итн.). Влага незабавно да се избърсва от повърхността.
- RO Toate suprafețele laminate în culoarea lemnului. Pentru curățire se folosește o cârpă ușor umezită după care se șterge imediat cu o cârpă uscată. Nu este recomandabil să se plaseze în locuri umede (bucătărie, baie, etc). Trebuie îndepărtată imediat orice urmă de umezeală.

